

THERMOWOOD.COM

||| Powered by Novawood Technology

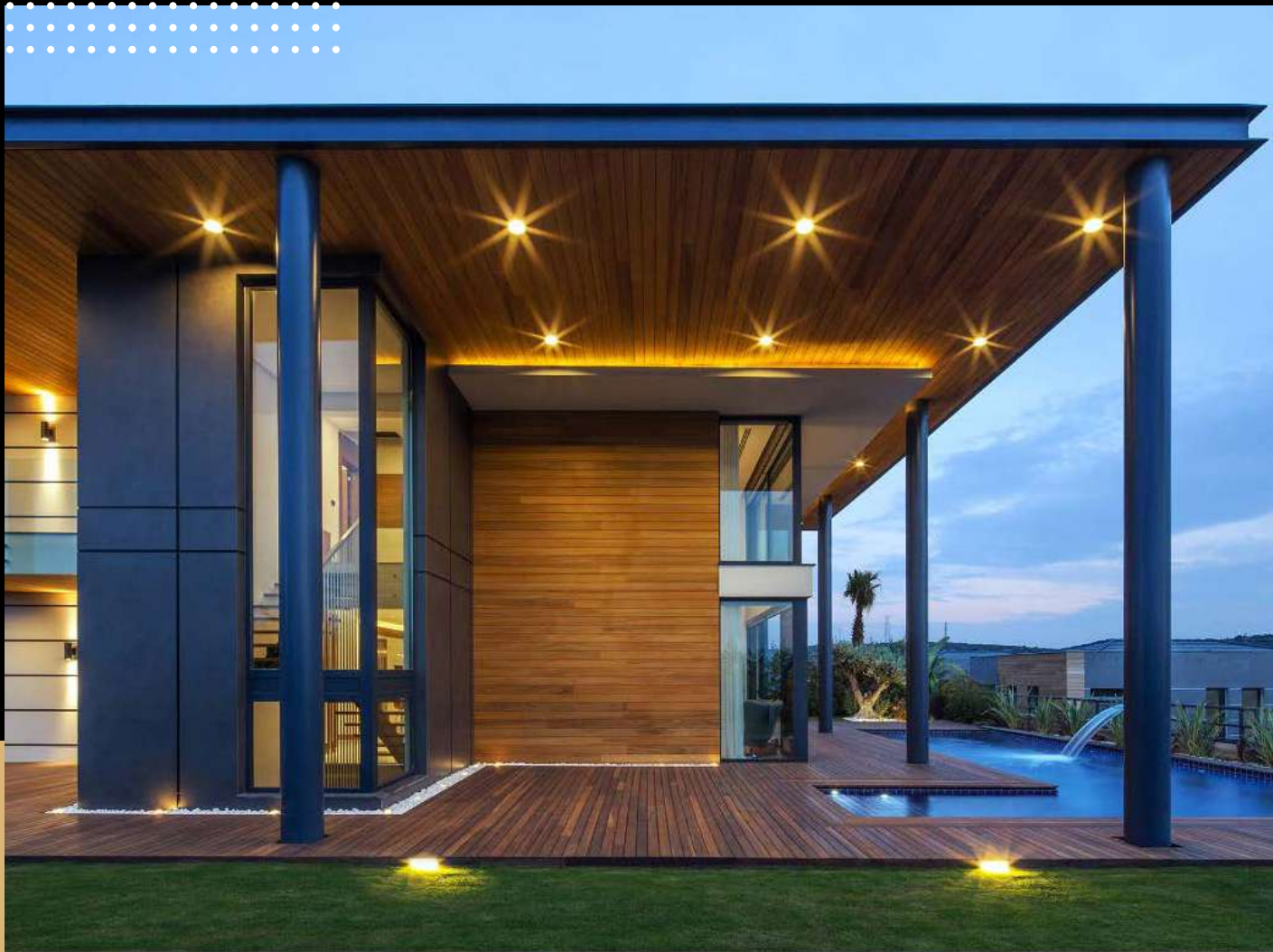

Thermowood Product Catalog

Interior and Exterior

INDEX

FACTORY & PRODUCTION	4
THERMO CLADDING	19
Nova-Ash Cladding	21
Nova-Iroko Cladding	23
Nova-Pine Cladding	25
Nova-Ayous Cladding	27
Cladding Profile Types	29
THERMO SANSHADE & PERGOLA	33
Sunshade	35
Sunshade Dimensions & Profiles	37
Nova-Pergola	39
THERMO DECKING	43
Nova-Ash Decking	45
Decking Profile Types	47
THERMOWOOD IN 6 CONTINENTS	74

As Thermowood, we set out to transform the weaving texture of the “tree” into the texture of “life”. Our aim was to transform the most beautiful gift of nature into living spaces that breathe. At the point we have reached today, we feel that we are bringing the nature one step closer to humans through each new design developed.

While trying to preserve the forest richness of our world with the sustainable solutions, we embrace the “long life span” as the most important brand value of our products.

We are inspired by the nature itself in terms of harmony and aesthetics, and we preserve our products with the most advanced thermal modifications method “Thermowood” for ultimate “durability” and “endurance”.

We have a justified pride in our position as being the first company introducing the thermal modifications technology “thermowood” in Turkey. We develop and direct every stage of the production process with innovative approaches which add value to the life. We strive to reinforce the wood products and wooden materials, which we regard as living materials, without compromising the aesthetic and naturalness of the product.

Our aim is to offer the precious gifts of the nature by preserving them in their most natural state.

“Nature cannot be considered apart from us, it is part of us.”

THERMOWOOD
||| Powered by Novawood Technology



FACTORY & PRODUCTION

Novawood is a world leading manufacturer of the thermowood sector with its high quality products, technological infrastructure and wide product range. The company produces 18,000 m³ of Novathermowood timber and 600,000 m² of finished products annually at its facilities located in Bolu Gerede, Turkey. Products manufactured at Novawood facilities are in compliance with the international quality standards. The quality is accredited as Novawood has participated in the research and quality control studies of the internationally accredited organizations in the sector.

Thermowood products mainly produced by Novawood include exterior claddings, deckings, sunshades, pergolas, door and window scantlings, materials for urban furnitures, blinds and shutters, solid and engineered floorings and interior wall coverings.

Novawood constantly renews and develops its product range in accordance with the needs and demands of the industry, without sacrificing quality. Working with a focus on the customer satisfaction and quality, Novawood also produces special products suitable for the large architectural projects and customer specific solutions.

INTERNATIONAL
ThermoWood
ASSOCIATION



* Look for our FSC® certified products



Novawood Headquarter ■



EUROPEAN
PROPERTY
AWARDS

Interior Design
WINNER
2016-2017

1st Award
Retail Architectures
2nd Award
Retail Interior

Novawood Showroom ■

NATURAL STATE OF WOOD

THERMOWOOD

Why does thermally modified wood get high marks for its increased stability and durability ratings? Heat treatment increases the stability and durability of wood. Wood is composed of 50% cellulose, 23% hemicellulose, 20% lignin, and 7% other organic compounds, called extractives. Heat treatment eliminates resin, all other extractives and bonding water called OH (Hydroxyl) groups from the wood. This process reduces water absorption of wood, consequently increasing decay resistance while decreasing swelling and shrinking. Another factor that contributes to the high durability of wood is the crystallization of cellulose. The change in hemicellulose increases the durability. Hemicellulose is separated into furfural and carboxylic acid. Caramelization of lignin, caused by heat, results in a darker colour appearance of the wood.

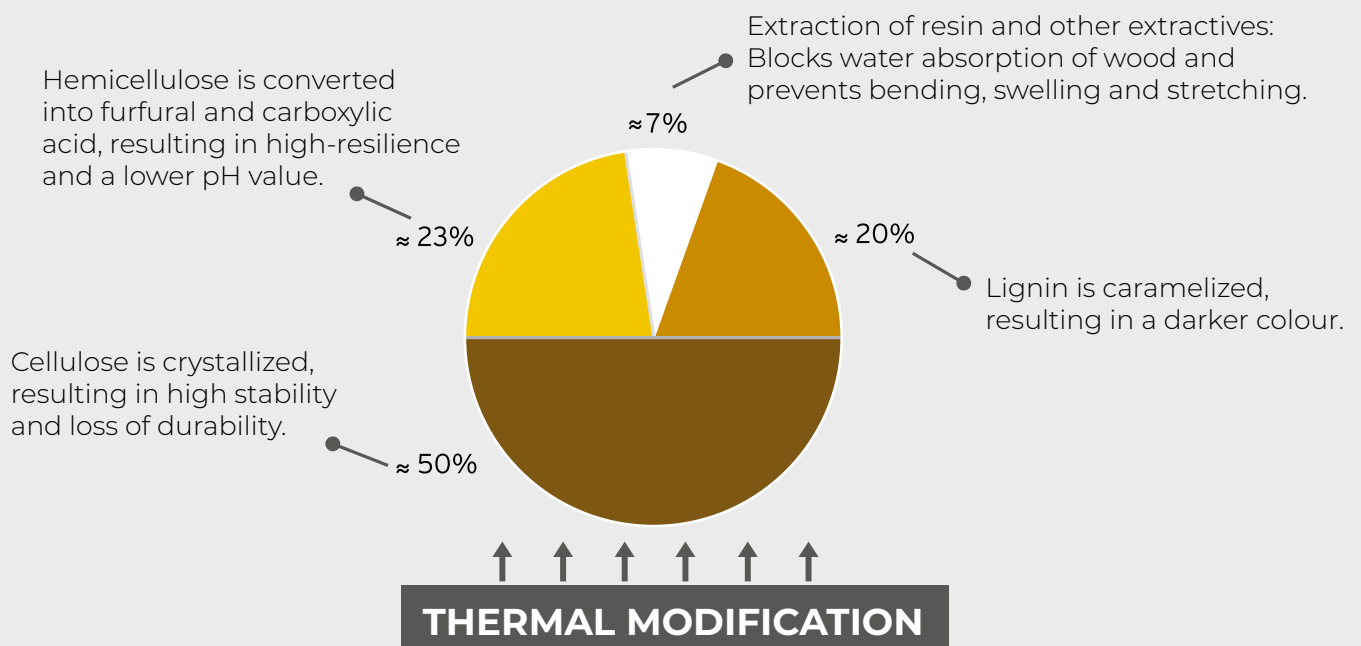

THERMOWOOD PROCESS

1 H_2O and OH bonding water are roaming inside the wood.

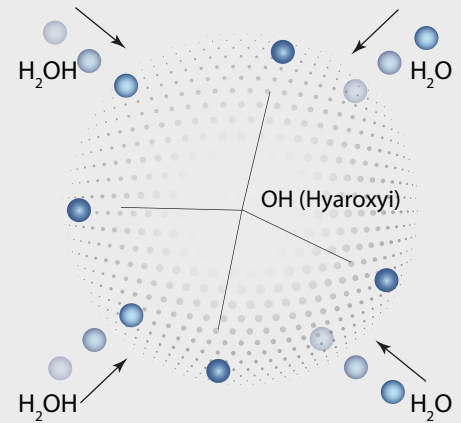

2 By regular drying (up to 90 °C) free waters are released out of the wood cell.

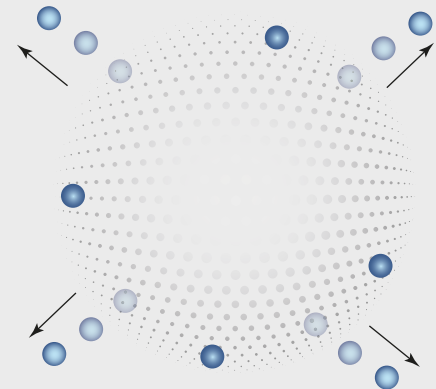

3 Through the Thermowood process (180 - 212 °C), the relative humidity (OH) is released from the cell and the working tendency of the wood is minimized.

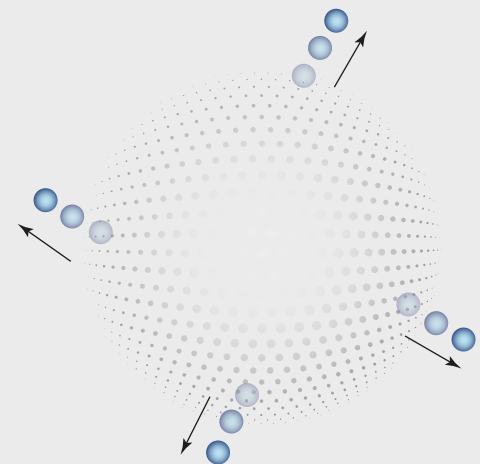





THERMOWOOD
Powered by Novawood Technology

Nova-Ash Decking

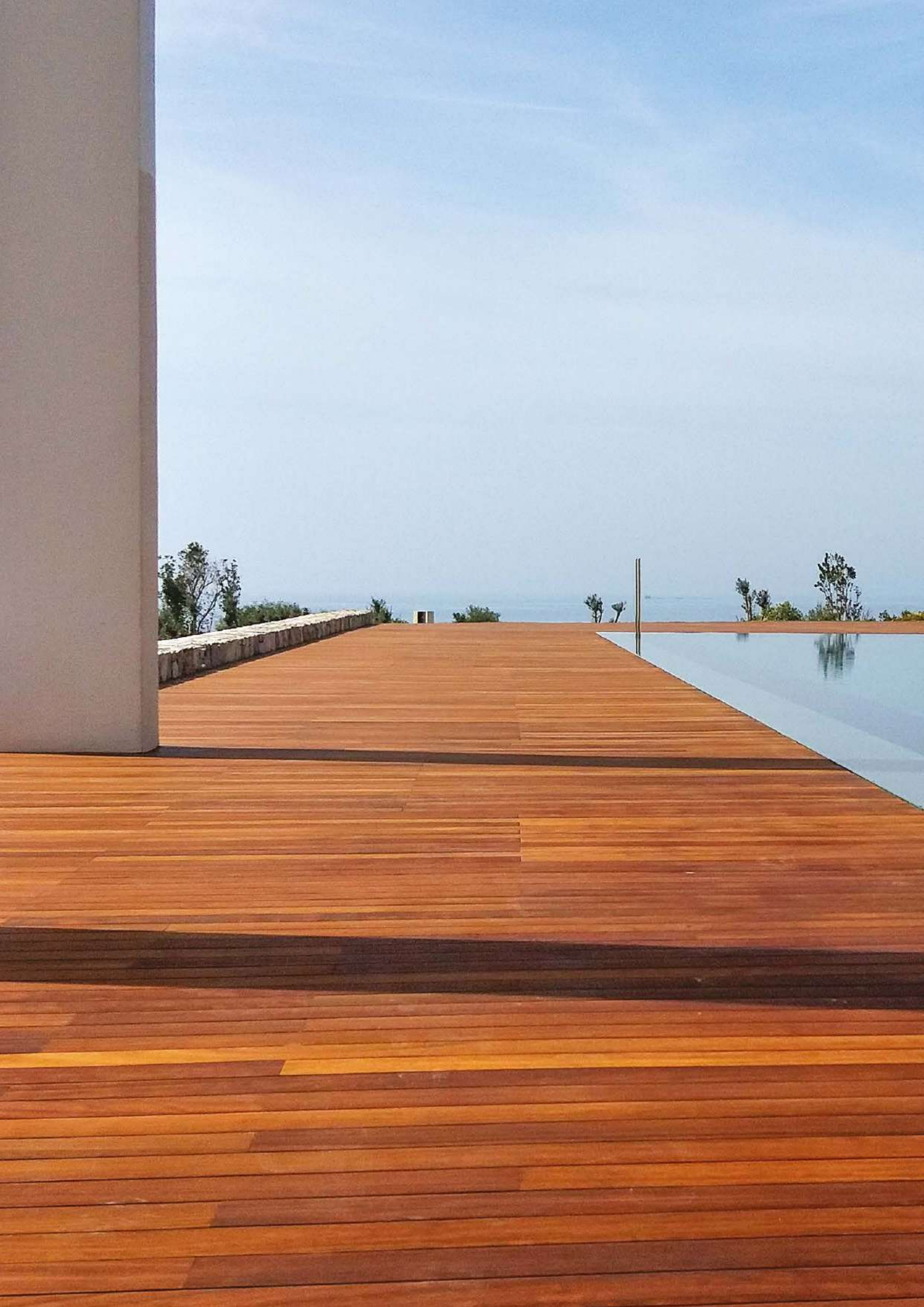

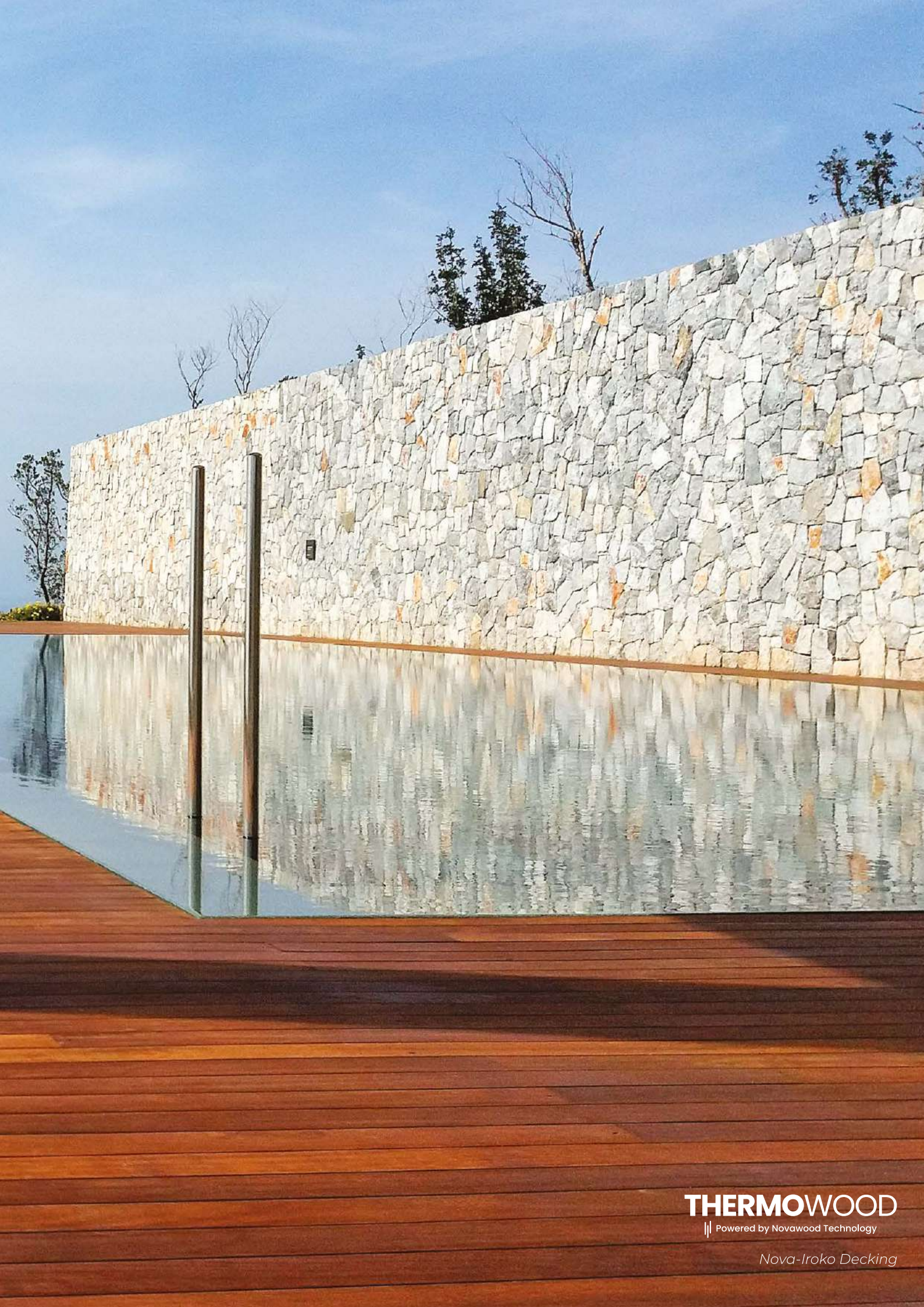

THERMOWOOD
Powered by Novawood Technology

Nova-Iroko Decking





THERMOWOOD

|| Powered by Novawood Technology

Nova-Iroko Sunshade & Decking



The most natural and technological method of wood preservation is Thermowood process. At the end of this process in which no chemicals are used, we obtain environmentally friendly, sustainable, weatherproof products with the highest quality.



Environmentally Friendly



Biological Resistance



Dimensional Stability

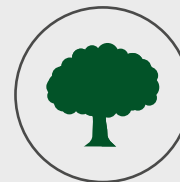

Sustainability

THERMOWOOD

Powered by Novawood Technology



Weatherproof



Easy Maintenance



High Quality



Non Toxic







Thermo Cladding is long-lasting and stable, allowing for horizontal and vertical applications with its size and profile options.

Thus, while supporting the design and aesthetic appearance of your buildings, it also provides a high resistance to all weather conditions.



THERMO

CLADDING

NOVA-ASH CLADDING



THERMOWOOD
Powered by Novawood Technology

Rönesans Biz Plaza - Mecidiyeköy ■

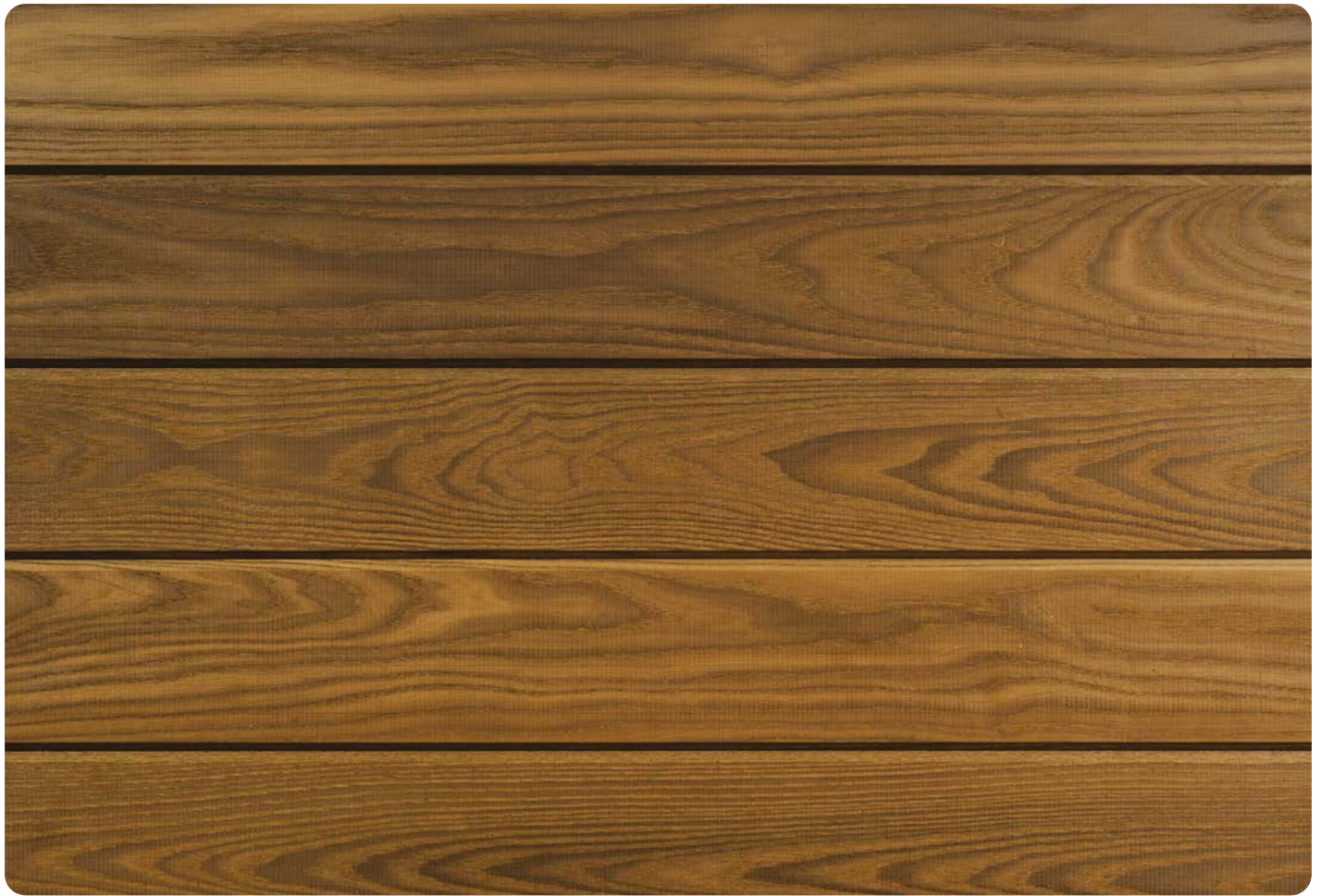

NOVA-ASH CLADDING

Ash is a hardwood with a high number of grains, and features an elegant look with its wavy texture. These features make Nova-Ash Cladding a multipurpose, aesthetic and durable material. If you seek an elegant look to highlight your buildings, durable and reliable Nova-Ash cladding is the right choice.



THERMOWOOD Ash cladding provides a flawless appearance and durability due to its wavy texture, performance and structural feature.

DIMENSIONS

Profile	Thickness (mm)	Width (mm)	Length (mm)
Standard	8	90 / 130	800 - 3600
Standard	10	90 / 130	800 - 3600
Standard	20	92 / 100 / 117 / 130 / 150 / 160 / 180	800 - 3600
Standard / Special	25	130 / 150	800 - 3600

NOVA-IROKO CLADDING

THERMOWOOD
Powered by Novawood Technology

Atılgan Royal Mavişehir ■

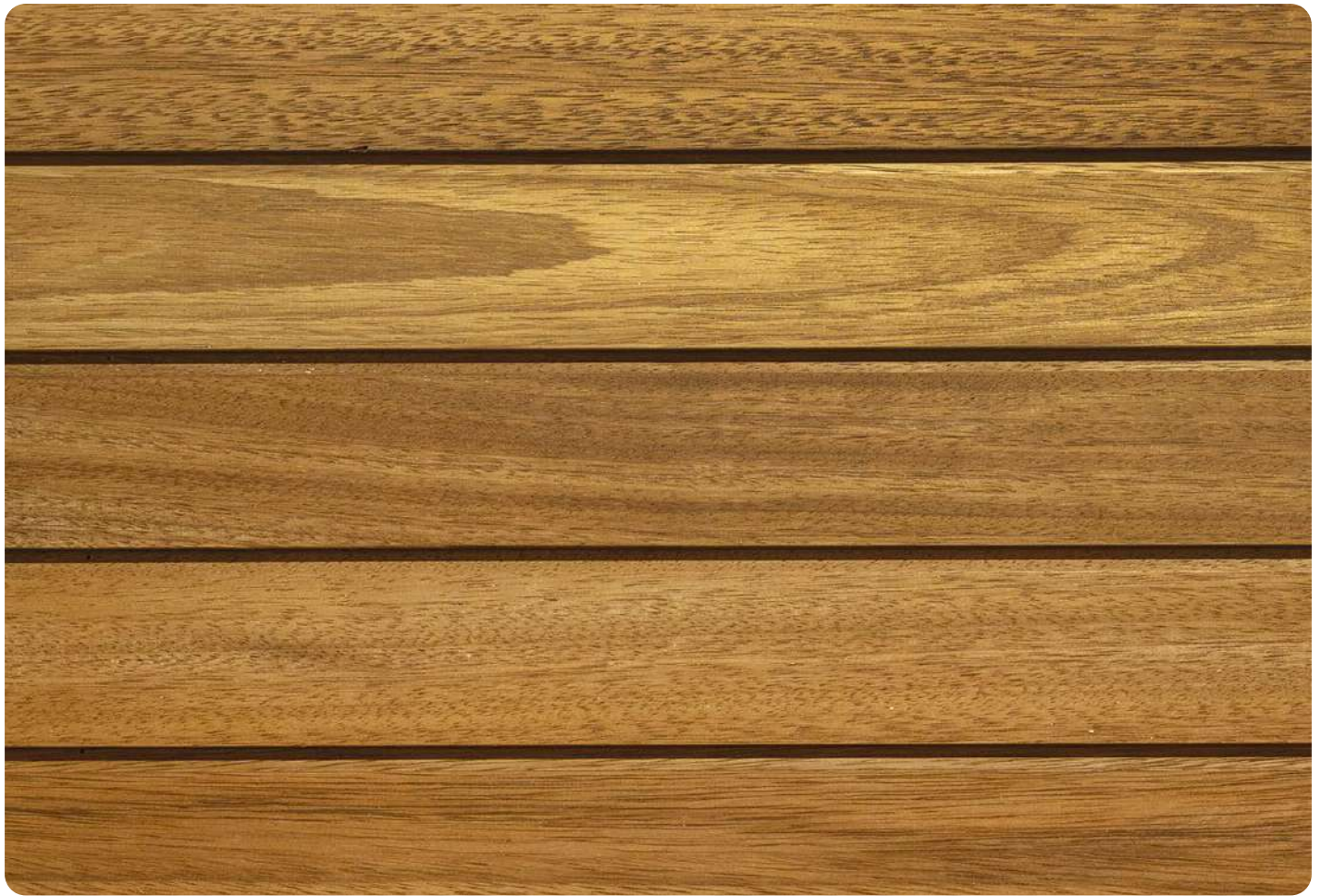

NOVA-IROKO CLADDING

The exotic Iroko is an ideal exterior cladding material with its durability, light amber colour and elegant look that captures perfection with its modern aspect.

In the process starting with the extraction from the nature, we make the exotic iroko tree, which stands out with its long biological life and simplicity, much more stable due to the thermowood process. Consequently, it becomes an ideal, problem-free material with a minimized working tendency. Nova-Iroko cladding drives your projects elite and modern by adding an aesthetic appearance with its elegance.



THERMOWOOD Nova-Iroko cladding will help you to capture a modern aspect at your spaces with its honey colour, uniform texture and plain appearance.

DIMENSIONS

Profile	Thickness (mm)	Width (mm)	Length (mm)
Clean-More	8	92	800 - 3000
Clean-More	10	92	800 - 3000
Standard / Sigma / Theta	19	92 / 120	800 - 3000

NOVA-PINE CLADDING

THERMOWOOD
Powered by Novawood Technology

Sekon Yapı ■



NOVA-PINE CLADDING

Being one of the most abundant tree species in the nature, the pine is transformed into Nova-Pine cladding through the thermowood process to present you the most natural one in the best way. It offers an ideal solution for those who seek a natural look on their facades and can't resist the charm of pine.



THERMOWOOD Its knotty structure is preferred by those who love the traditional. With its unique harmony with the nature, perfect adaptation to all whather contitions, cost-benefit balance, Nova-Pine claddings are carefully produced for your buildings.

DIMENSIONS

Profile	Thickness (mm)	Width (mm)	Length (mm)
Standard	16	92	1000 - 5100
Standard	19	92 / 118 / 120 / 138 / 140	1000 - 5100
Standard	20	118 / 120	1000 - 5100
Standard / Special	26	92 / 118 / 120 / 138 / 140	1000 - 5100



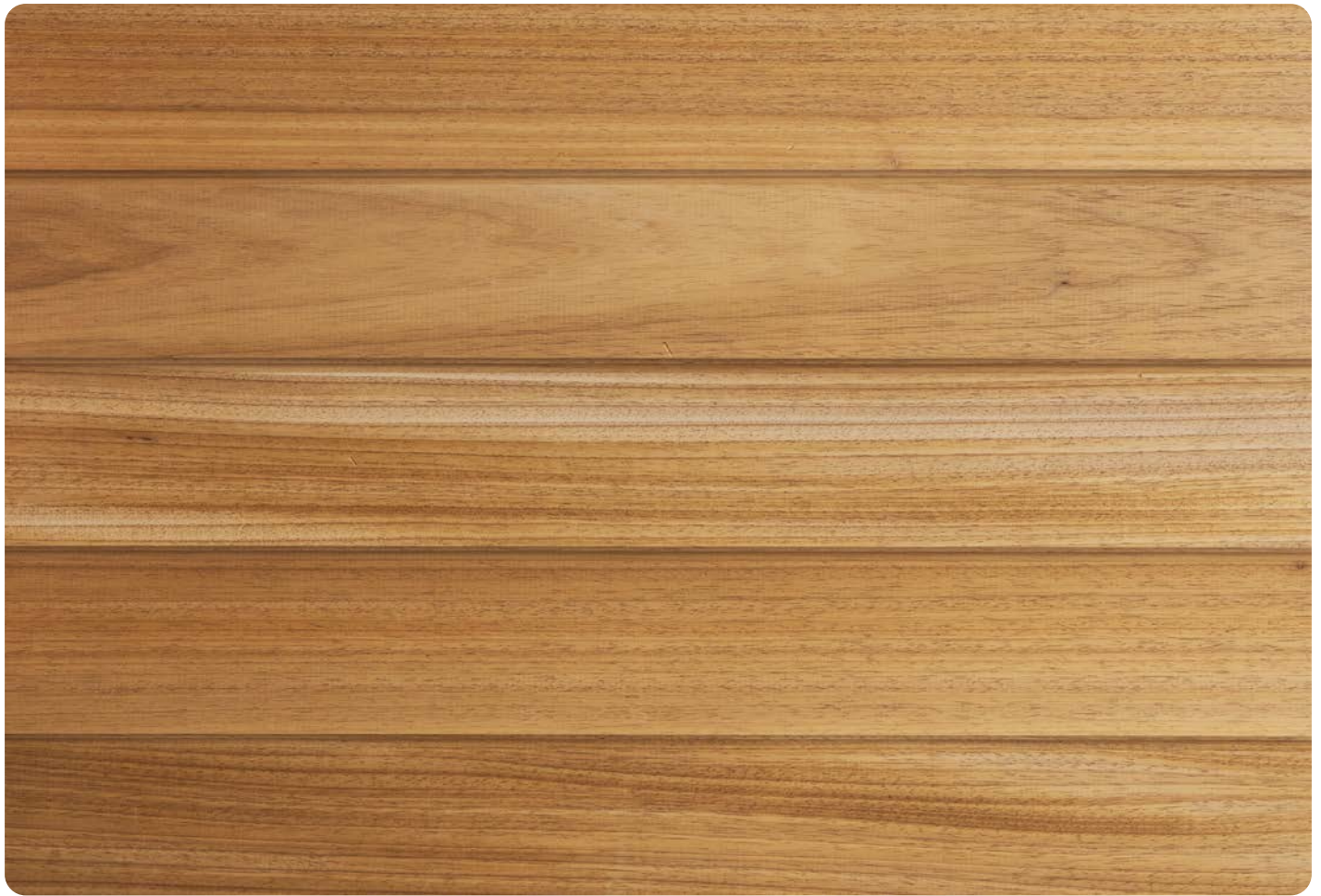

NOVA-AYOUUS CLADDING

Nova-Ayous has a highly admired and particularly preferred yellow-brown color, and it becomes an indispensable tropical wood option on the exteriors with its knot-free structure and unique texture. Simultaneously, it provides a great convenience in the applications by not imposing any extra load on the facades through its light structure. All the durability and dimensional stability features of our other thermowood products are also valid for Nova-Ayous claddings.



THERMOWOOD Nova-Ayous claddings are presented as an economical alternative with their smooth structure and easy processability, simple and elegant structure.

DIMENSIONS

Profile	Thickness (mm)	Width (mm)	Length (mm)
Clean - More	8	92	1000 - 4000
Standard	16	92	1000 - 4000
Standard	18	92	1000 - 4000
Standard	20	92 / 140	1000 - 4000
Standard / Special	25	90 / 120 / 130 / 140 / 150	1000 - 4000

NOVA-ASH CLADDING



THERMOWOOD
Powered by Novawood Technology

Babadağ Ski Resort

STANDARD
PROFILES

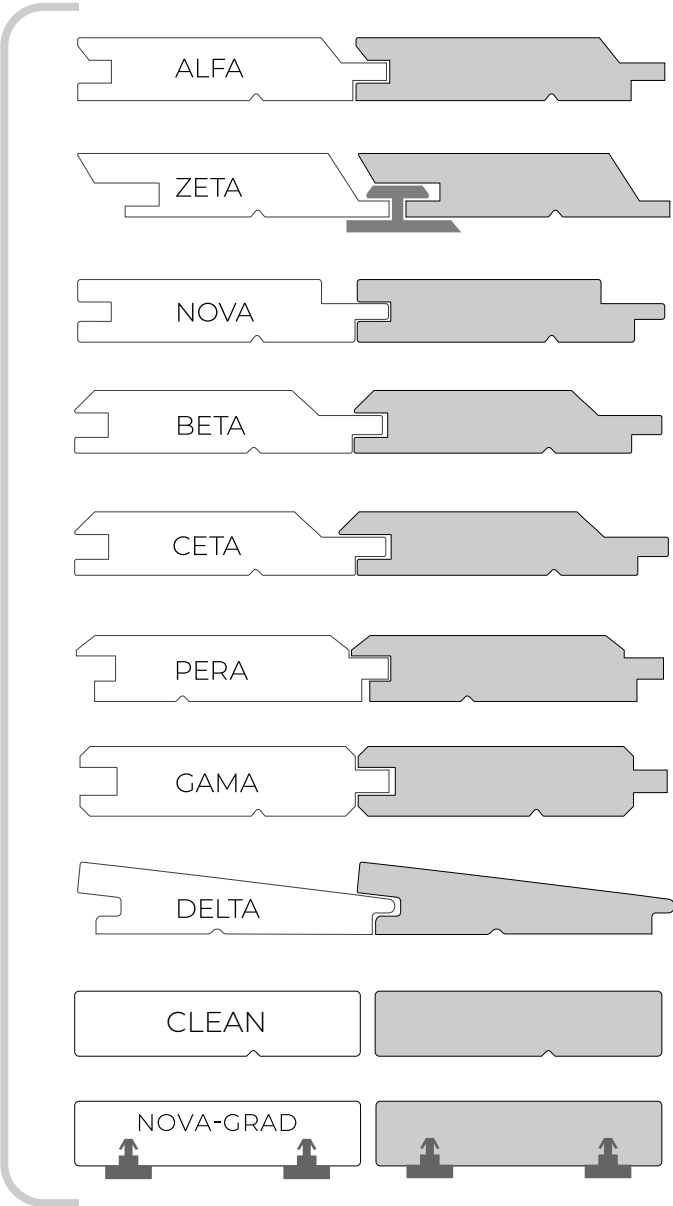

SPECIAL
PROFILES

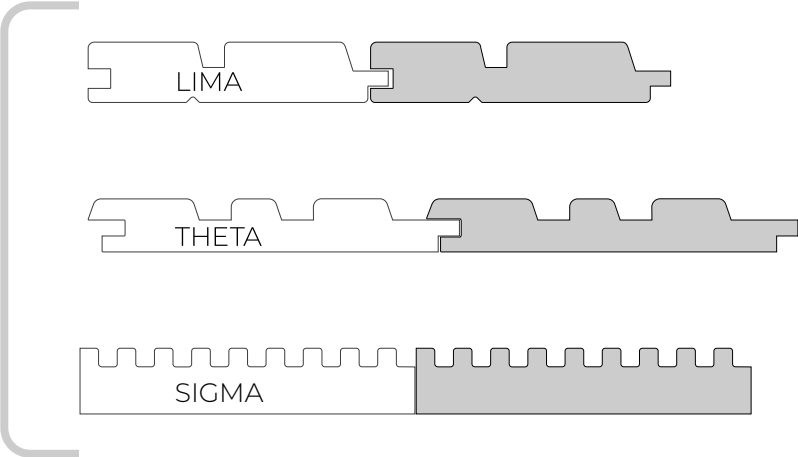







Thermo-Sunshade products are an ideal solution and offers a modern cladding alternative for buildings that are exposed to sunlight throughout the day.

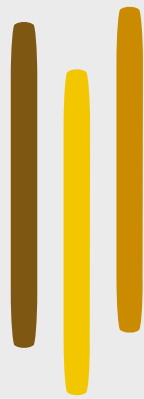

THERMO

SUNSHADE
& PERGOLA





Vicem Villas



THERMOWOOD Thermo-sunshades do more than simply protecting from the effects of the sun; but also add a decorative value to your living spaces.



THERMOWOOD While optimally benefiting from daylight, your living spaces will take on a striking beauty. Experience the confort of wood with its useful and functional structure. We united shade and sun in wood.



Ulus Savoy



■ THERMO-SUNSHADE



THERMOWOOD
||| Powered by Novawood Technology

Sarp Construction ■

SUNSHADE DIMENSIONS & PROFILES

THERMOWOOD
Powered by Novawood Technology

Nova-Ash Sunshade

Profile	Thickness(mm)	Width(mm)	Lenght(mm)
Clean / More / Rombus	20	42 / 55 / 65 / 90 / 112 / 130	1200 - 3600
Clean / More / Rombus	25	42 / 55 / 65 / 130	1200 - 3600
Clean / More / Rombus	30	65 / 130	1200 - 3600
Clean / More / Rombus	40	40 / 65 / 90 / 115 / 130	1200 - 3600
Omega	40	40	1200 - 3600

THERMOWOOD
Powered by Novawood Technology

Nova-Iroko Sunshade

Profile	Thickness(mm)	Width(mm)	Lenght(mm)
Clean / More / Rombus	20	40 / 90	800 - 3000
Clean / More / Rombus	40	40	800 - 3000
Omega	40	40	800 - 3000

THERMOWOOD
Powered by Novawood Technology

Nova-Pine Sunshade

Profile	Thickness(mm)	Width(mm)	Lenght(mm)
Clean / More / Rombus	19	42 / 55 / 92 / 118	1000 - 5100
Clean / More / Rombus	26	42 / 55 / 65 / 92 / 118 / 138	1000 - 5100
Clean / More / Rombus	42	42 / 65 / 90 / 138	1000 - 5100
Omega	42	42	1000 - 5100

THERMOWOOD
Powered by Novawood Technology

Nova-Ayous Sunshade

Profile	Thickness(mm)	Width(mm)	Lenght(mm)
Clean / More / Rombus	20 / 42	42 / 65 / 90 / 140	1000 - 4000
Omega	42	42	1000 - 4000

THERMOWOOD
Powered by Novawood Technology

Nova-Tulipwood Sunshade

Profile	Thickness(mm)	Width(mm)	Lenght(mm)
Clean / More / Rombus	20 / 42	42 / 65 / 130	1000 - 4200
Omega	40	40	1000 - 4200

PROFILES

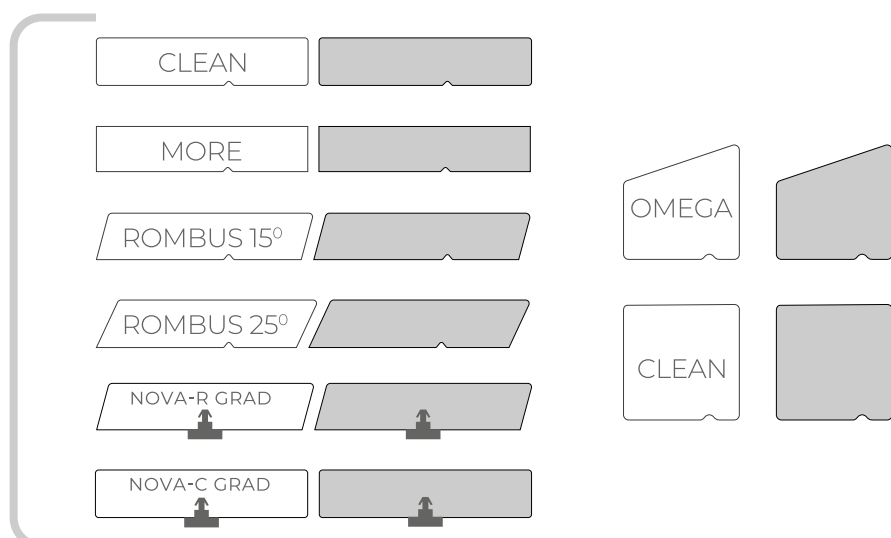



Thermo-Pergola is one of the very special solutions that will add elegance and value to your spaces. Thermo-Pergola, which you can use for shading in areas where you rest, relax and enjoy, as well as for purely aesthetic reasons, will fascinate those who see it with its elegance.



As lamination process is applied to have large sizes, products in special sizes can be provided for your projects.

Folkart

Thermo-Pergola is a natural and useful solution that will allow you to use unique designs for garden decorations.



Private Villa







Choose the most suitable product for you from the **Thermo-Decking** portfolio, enjoy life with a natural product that you will not give up stepping on for years.



THERMO

DECKING

NOVA-ASH DECKING



THERMOWOOD
Powered by Novawood Technology

Edition Hotel ■

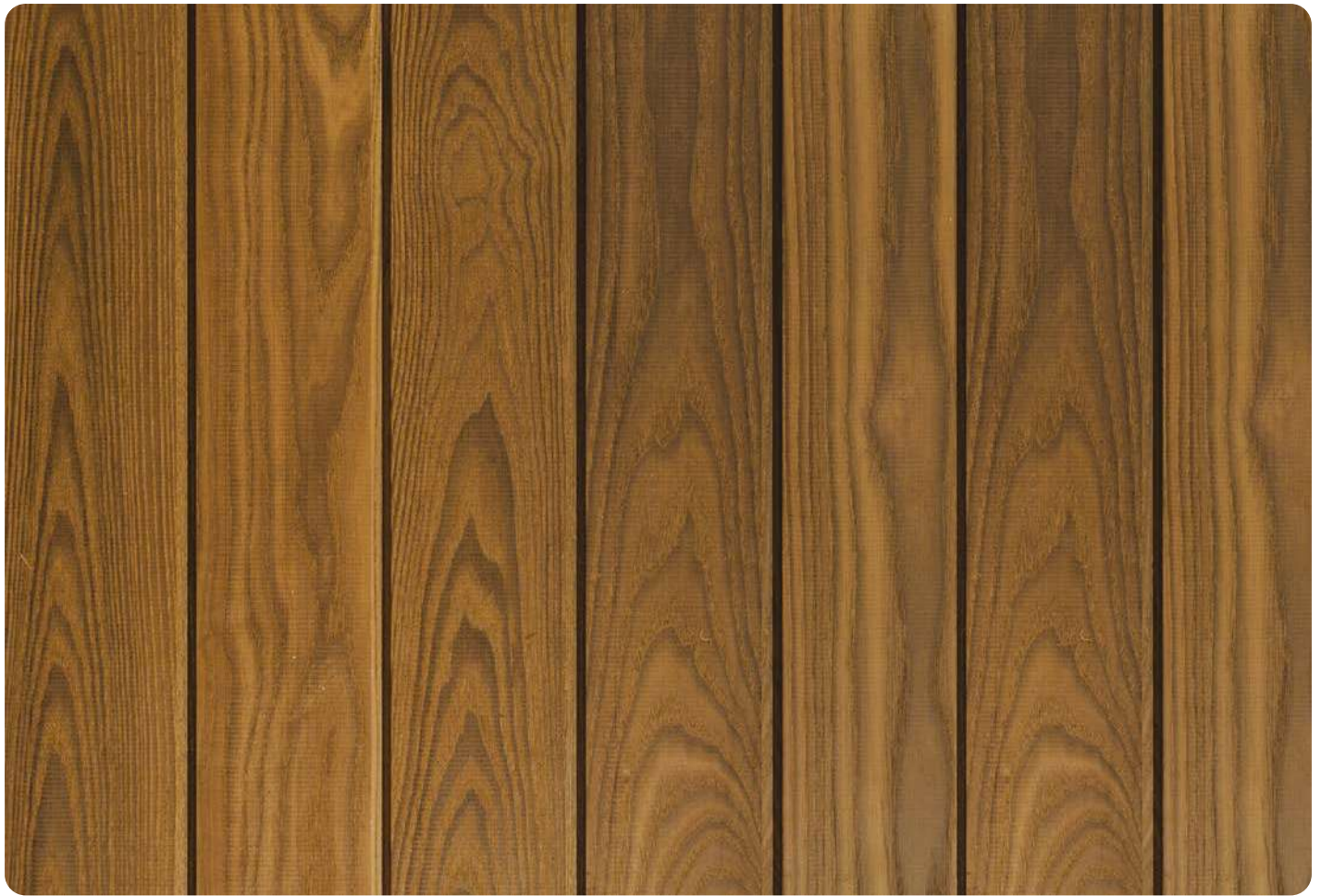

NOVA-ASH DECKING

Nova-Ash decking turns out to be an indispensable product for outdoor usage with its aesthetic appearance, long life span and durability. Through the enhancing process of Thermowood, the biological durability of Ash decking material increases and becomes resistant to the outdoor weather conditions.



THERMOWOOD Its attractive brown colour, beautiful grain structure, dimensional stability and technical features add value to the spaces and ensures optimum results.

DIMENSIONS

Profile	Thickness (mm)	Width (mm)	Length (mm)
Standard	20 / 21	80 / 90 / 112 / 125 / 130 / 140 / 150	800 - 3600
Standard	25	90 / 115 / 125 / 130 / 140 / 150 / 160	800 - 3600
Standard	30	90 / 115 / 130 / 150	1000 - 3000
Standard	40	65 / 90 / 115 / 130 / 150	1000 - 3600

NOVA-ASH DECKING



THERMOWOOD
Powered by Novawood Technology

STANDARD
PROFILES

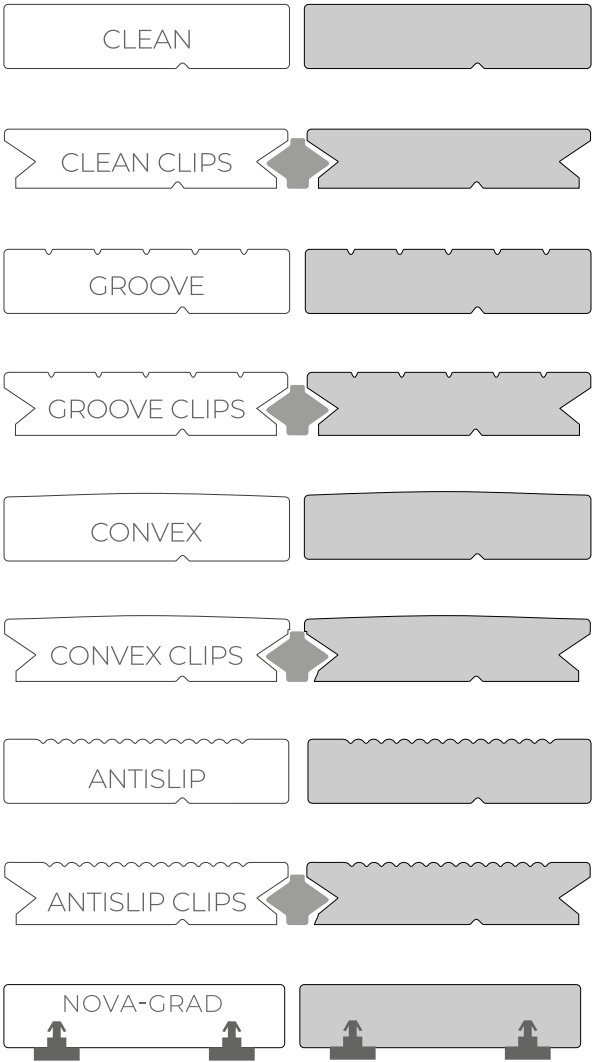

SPECIAL
PROFILES

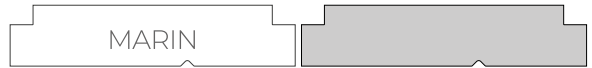





THERMOWOOD
Powered by Novawood Technology

Nova-Ash Cladding





THERMOWOOD
Powered by Novawood Technology

Nova-Iroko Decking





THERMOWOOD
Powered by Novawood Technology

Nova-Iroko Decking





THERMOWOOD

|| Powered by Novawood Technology

Nova-Ash Decking & Ceiling





THERMOWOOD
Powered by Novawood Technology

Nova-Iroko Decking





THERMOWOOD
Powered by Novawood Technology

Nova-Ash Cladding





THERMOWOOD
Powered by Novawood Technology

Naturally Grayed Ash Decking





THERMOWOOD
Powered by Novawood Technology

Nova-KD Iroko Decking





THERMOWOOD

Powered by Novawood Technology

Nava-Pine Sunshade





THERMOWOOD
|| Powered by Novawood Technology

Nova-Ash Decking





THERMOWOOD
Powered by Novawood Technology

Nova-Ash Cladding





THERMOWOOD
Powered by Novawood Technology

Nova-Ash Decking





THERMOWOOD
|| Powered by Novawood Technology

Nova-Ayous Cladding

- AFGHANISTAN
- ALBANIA
- ANTARTICA
- AUSTRIA
- BAHRAIN
- BELGIUM
- BRITAIN
- BULGARIA
- CANADA
- CHINA
- CROATIA
- CYPRUS
- CZECH REPUBLIC
- DENMARK
- DJIBOUTI
- EGYPT
- ESTONIA
- FINLAND
- FRANCE
- GEORGIA
- GERMANY
- GHANA
- GREECE
- HONG KONG
- HUNGARY
- IRANIAN
- IRAQ
- ISRAEL
- ITALY
- JAPAN
- JORDAN
- KAZAKHISTAN
- KOSOVO
- KUWAIT
- LEBANON
- LIBYA
- LIECHTENSTEIN
- MEXICAN
- MOROCCO
- NETHERLANDS
- NORWAY
- OMAN
- PAKISTAN
- PALESTINE
- PORTUGAL
- ROMANIA
- RUSSIA
- SAUDI ARABIA
- SERBIA
- SINGAPORE
- SLOVAKIA
- SOUTH KOREA
- SPAIN
- SWEDEN
- SWITZERLAND
- TAJIKISTAN
- UAE
- UGANDA
- UKRAINE
- USA
- UZBEKISTAN
- VIETNAMESE



NOVAWOOD IN 6 CONTINENTS



THERMOWOOD.COM

||| Powered by Novawood Technology

United States

20807 Biscayne Boulevard, Aventura, Florida
+1 (305) 586-5371 | +1 (786) 206-8899 | info@thermowood.com

Turkey

Küçükçamlıca Mah. Bulgurlu Cad. No: 32 Üsküdar-İstanbul
+90 216 545 66 82

www.thermowood.com